

ESTATE PLANNING WORKBOOK

PREPARED BY

**KAIN &
BURKE, PC**

PROFESSIONAL, THOROUGH & CARING LEGAL SERVICES

225 N. 5TH STREET, SUITE 611
PO BOX 1981
GRAND JUNCTION, CO 81502
(970) 241-2969
(970) 241-3129 FAX
WWW.KAINLAW.COM

COPYRIGHT 2007 KAIN & BURKE, PC

The Purpose of this Book

Estate planning is a scary proposition to many people. It certainly is important that your estate plan be properly drafted so that your wishes will be carried out at death and your loved ones are protected. This book is not a how-to or do-it-yourself book. It takes years of training, experience and expertise to learn how to draft an estate plan properly. This is something you should not try to do without professional help. On the other hand, this book will help familiarize you with some of the basic concepts involved in estate planning so you can better work with your attorney in drafting an estate plan that meets your needs and that of your heirs.

Michael P. Burke earned a B.A. in Business Administration from Mesa State College, an M.B.A. in Business Administration, and a Juris Doctorate at the University of Denver in 1993. He specializes in Estate Planning, Probate, and Business Law. He has completed a number of American Bar Association Estate Planning courses, and teaches numerous seminars on estate planning.



Michael P. Burke



Stephanie R. Holguin

Stephanie R. Holguin earned her Juris Doctorate with honors from the University of Wyoming College of Law in May 2012. Stephanie is bilingual, and practices in the areas of business law, estate planning, family law, probate, juvenile law, civil litigation, and real estate law. She was selected as the 2011-2012 Domestic Violence Clinic Outstanding Student and the Clarence A. Brimmer Scholar in 2011. Stephanie was a research assistant for a law school professor, focusing her research on franchiser liability and agency law.

Andrew Smith graduated with a Business Management degree from the Marriott School of Management at Brigham Young University in 2004. During law school Andrew earned the CALI Award for Taxation of Property Transfers. He received his Juris Doctorate from the University of South Carolina School of Law in 2010. Andrew works in the areas of business law, estate planning, criminal law, family law, civil litigation, and real estate law. He is licensed to practice law in South Carolina, Colorado and Arizona.



Andrew Smith



Jill Cenamo

Jill Cenamo holds a B.A. Degree in Sociology (Criminal Justice) and Psychology from the University of Colorado (Colorado Springs). She was awarded Honors in Sociology and earned a Certificate in Criminology and Justice Studies. Jill received her Juris Doctorate from the University of Wyoming College of Law in May 2012. She was a Deputy D.A. for six years in Colorado's 11th Judicial District. Jill practices in criminal law, business law, civil litigation, estate planning, real estate law, probate, family law, and juvenile law.

2023 ESTATE AND GIFT TAX ADDENDUM

\$12,920,000 is exempt from estate and gift taxes for gifts made in 2023 or decedents dying in 2023. A married couple with two bypass trusts can pass \$25,840,000 free of taxes at death in 2023.

However, if the first spouse to die leaves everything outright to the surviving spouse without a bypass trust, the exemption of the first spouse to die potentially is wasted. This oversight can be corrected under the “portability provisions” of current law by filing an estate tax return making an election to let the surviving spouse “borrow” the decedent’s unused \$12,920,000 exemption. Nevertheless, a bypass trust for each spouse still is good planning to take advantage of removing appreciating assets, including growth between the date of death of the first spouse and date of death of the second spouse to die. There are pros and cons regarding portability that should be considered in planning, such as the loss in step up in basis at the death of the second spouse. Portability also raises other issues, such as for example whether the surviving spouse will receive the benefits of asset protection from creditors. Generation Skipping Trusts also may have special problems if portability is relied on.

In 2023 there is a \$17,000 per donee, per annum gift tax exclusion.

The step up in basis to date of death value for calculating capital gains taxes on property inherited from a decedent will apply for deaths occurring in 2023.

The exemptions are subject to the actions of Congress. Not many years ago, the exemption was \$1,000,000. It is unknown what Congress may do in the future, and some expect the exemptions could be scaled back significantly in the future. If there is a time where the value of your estate exceeds the exemption, it would be wise planning for a couple to sign two bypass trusts and take other tax minimizing actions.

The Purposes of Estate Planning

- ◆ Planning for incapacity.
 - ◆ Appointing fiduciaries.
 - ◆ Setting up a Will or Trust.
 - ◆ Providing for efficient and inexpensive settling of your estate after death.
 - ◆ Setting out who will receive your property after death and how your debts and expenses will be paid.
-

Estate planning is the process by which an attorney assists a client in deciding what the client's estate planning goals are, and what the most effective method of carrying out those goals would be. A qualified estate planning specialist will consider the use of numerous estate planning techniques such as a Last Will and Testament, Living Trust, Joint Tenancy Property, Powers of Attorney, and Living Wills. It is important that the entire plan be coordinated.

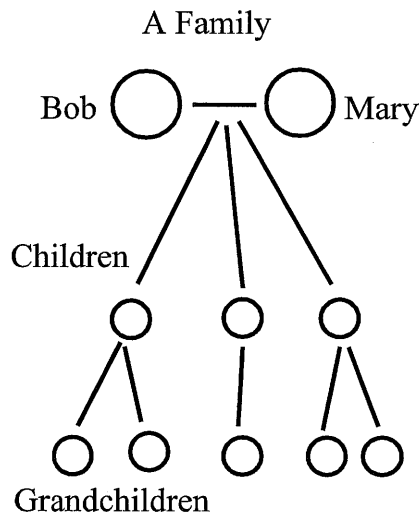

Notes:

Estate Planning Goals

- ◆ Making sure that your heirs receive their property at your death.
 - ◆ Avoiding taxes.
 - ◆ Avoiding the delays of Probate.
 - ◆ Avoiding the expense of Probate.
 - ◆ Obtaining the privacy of a Trust.
 - ◆ Transferring out-of-state property.
-

Part of the process of estate planning is deciding what your particular goals are. Perhaps you are most interested in avoiding Probate. Perhaps you would like to see your loved ones receive your property with the least possible expense and hassle. Perhaps you want the privacy of a Trust, or the asset management that a bank trustee can provide for your children and grandchildren. Whatever your goals, it is important that they be clearly in mind and carried out by the attorney.

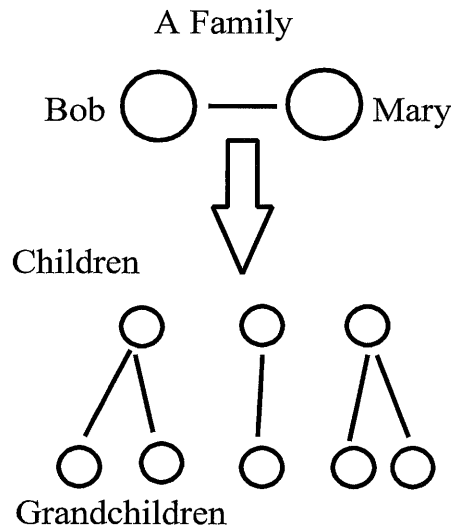

Notes:

How Probate Works

1. Lodging the Will.
2. Appointing the Personal Representative.
3. Issuing Letters Testamentary.
4. Marshaling the assets.
5. Paying debts and administrative expenses.
6. Transferring assets to the heirs.
7. Selling assets and distributing the net proceeds of the estate.
8. The estate Inventory and Accounting.
9. Publishing the Notice to Creditors.
10. Closing the estate.

Probate is the process by which a **Last Will and Testament** is lodged with the **Probate Court** so that the provisions of the Will can take effect. After the Will is lodged with the Court, the Court will issue a document known as the “**Letters Testamentary**.” This document allows the **Personal Representative**, also known as the **Executor**, to transfer assets to the heirs. Normally an estate bank account is opened, and as each asset is liquidated, the proceeds are placed into the estate bank account. The debts and expenses of the estate are paid from that account, and after all of the assets have been liquidated and all of the debts and expenses paid, the balance remaining in the account is distributed to the heirs according to the Will. There are statutory requirements for an **Accounting** and an **Inventory**. In addition, a **Notice to Creditors** is run in the paper for three weeks, giving creditors four months to come forward or be forever foreclosed from asserting their claims. By law, a Probate may not be closed in less than six months.

Notes:

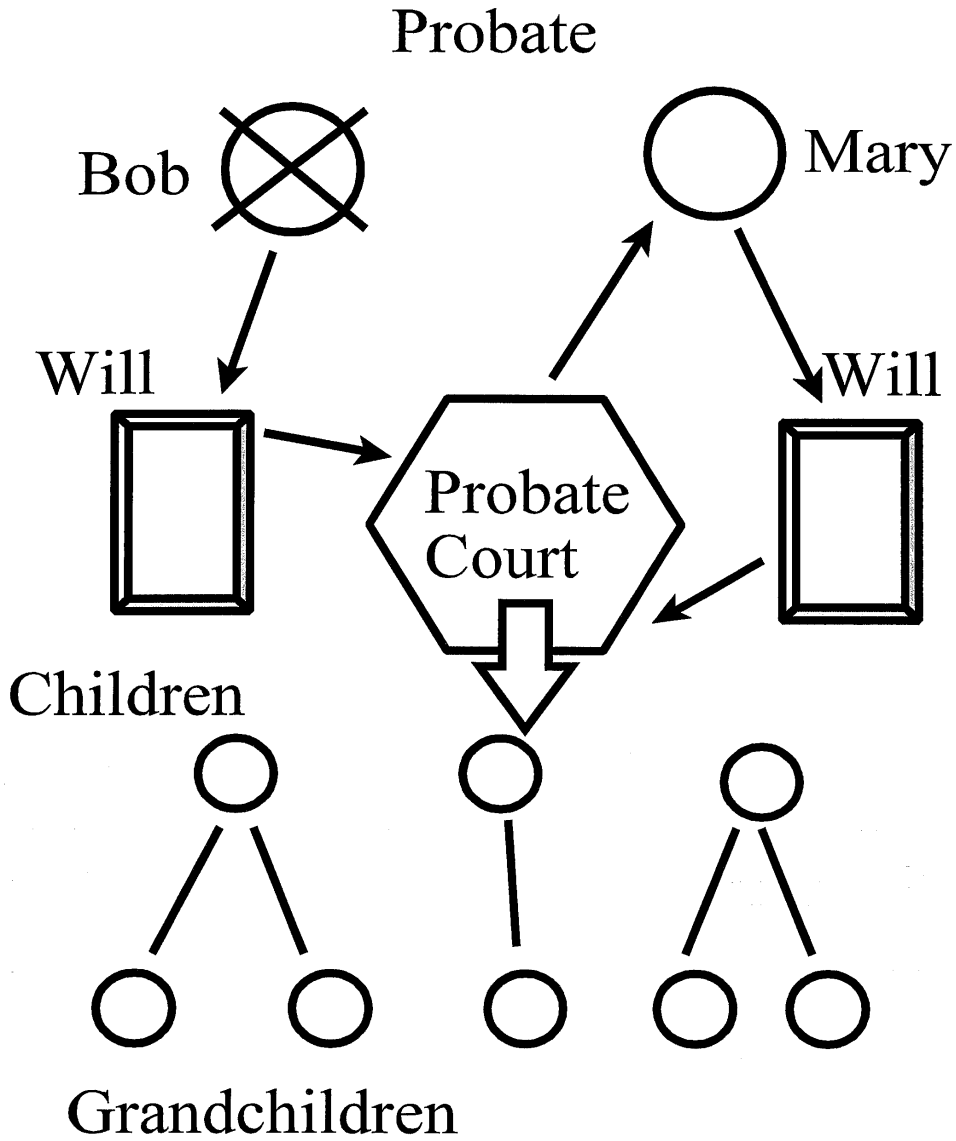

Notes:

Assets Subject to Probate

- ◆ Those titled in the decedent's name.
- ◆ Those held in tenancy in common.

Assets Not Subject to Probate.

- ◆ Joint tenancy.
- ◆ Payable on death accounts.
- ◆ Transferred on death accounts.
- ◆ Life insurance.
- ◆ Living trust.
- ◆ Retirement plans.
- ◆ Life estates.

Normally the assets subject to Probate include the assets titled in the decedent's name. This can include a decedent's share of property owned as tenants in common.

Assets that are held in joint tenancy, payable on death accounts, transferred on death accounts, life insurance, property owned by a living trust, annuity proceeds, retirement plans with named beneficiary, and real estate in which a decedent owns a life estate, are not subject to Probate. This means that they pass to the heirs outside the Will without going through the Probate Court.

Notes:

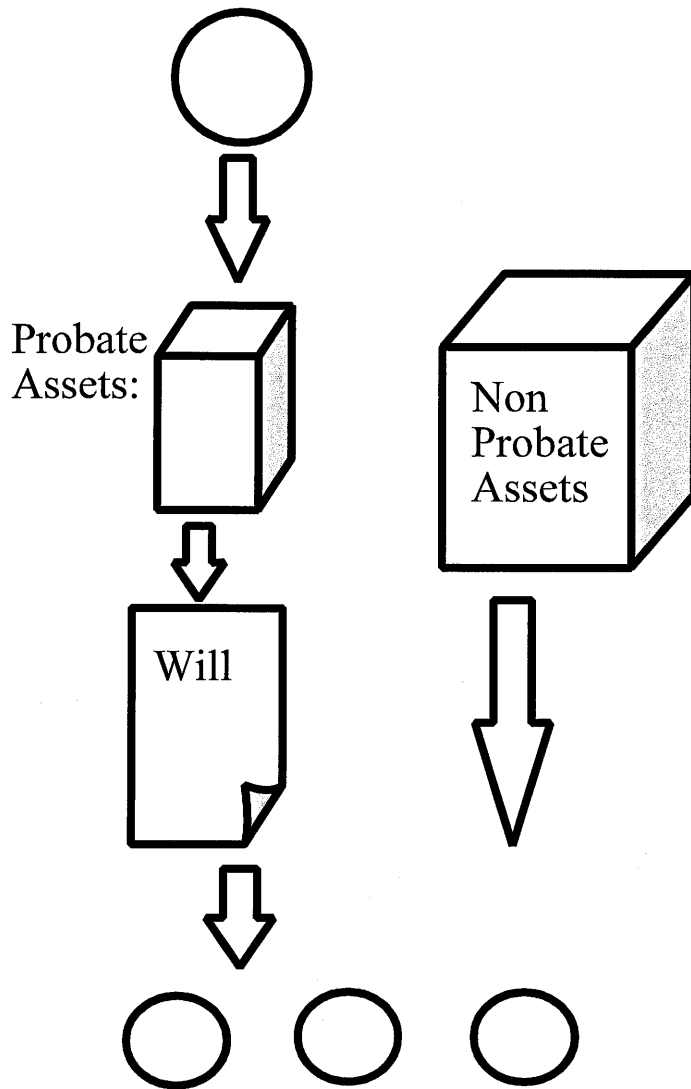

Notes:

Advantages of Probate

- ◆ Cutting off creditors' claims.
- ◆ Appointment of a Guardian for minor children.
- ◆ Drafting a Will is relatively inexpensive.

Probate does have certain advantages. For one thing, Probate allows for a notice in the newspaper to run for three weeks giving all creditors four months to come forward. Any creditors who fail to file a claim with the Probate Court or with the Personal Representative within four months may forever lose their claims. This has the advantage of allowing the Personal Representative to make distribution to the heirs without fear that further creditors may later come forward and sue the heirs or the estate. The Probate process can be expensive, but an advantage of writing a Will is that the Will can be drafted fairly inexpensively compared to the cost of setting up a Trust. Also, a Will is the easiest way to appoint a Guardian for minor children.

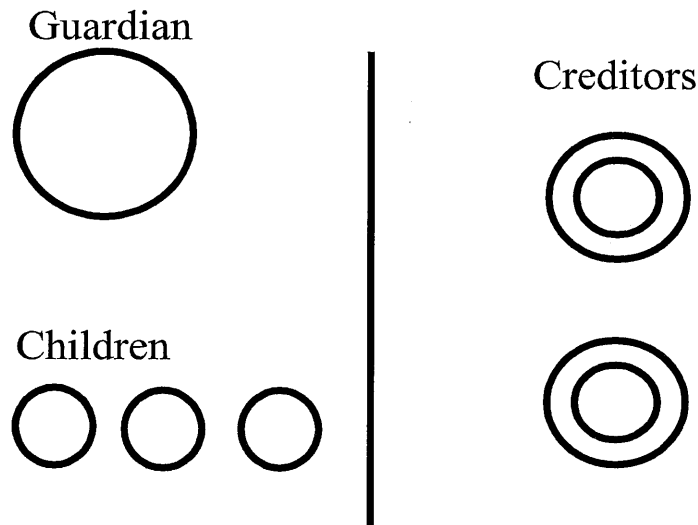

Notes:

Disadvantages of Probate

- ◆ Expensive.
 - ◆ Time-consuming.
 - ◆ Ancillary Probate is needed for property in other states.
 - ◆ Lack of privacy.
-

Probate can be very expensive. It is also time-consuming and frustrating for many people. The law does not allow a Probate Estate to close in less than six months, and often it takes longer than six months to make sure that all assets have been transferred and bills paid. Further, Probate does not have the advantages of privacy that a Trust has. Even with Colorado's relatively simplified Probate System, the Probate process generally takes much longer and costs much more to administer than does a Trust.

Notes:

Advantages of a Living Trust

- ◆ Avoids the frustrations of Probate.
- ◆ Avoids the time and expense of Probate.
- ◆ Privacy.
- ◆ Avoids ancillary Probate for out-of-state real estate.
- ◆ Avoids a conservatorship or a guardianship if disabled.
- ◆ Much less expensive than Probate.

A *Living Trust* can avoid Probate completely if all assets have been transferred to the Living Trust during your life. It may be somewhat more expensive to set up a Trust than to set up a simple Will. But overall, with the tremendous savings in Probate costs, your children or other heirs will receive far more of your estate with a Living Trust than with a Probate of a Will. Further, a Living Trust can provide privacy since there is no requirement that the Trust be lodged with the Court. Normally, only a one-page *Trust Registration Statement* is lodged with the Probate Court after death, which means that the dispositional provisions of the Trust are kept private. Another advantage of a Living Trust is that out-of-state real estate can be transferred with a Living Trust without the necessity of opening an *Ancillary Estate* where the vacation home is located.

Notes:

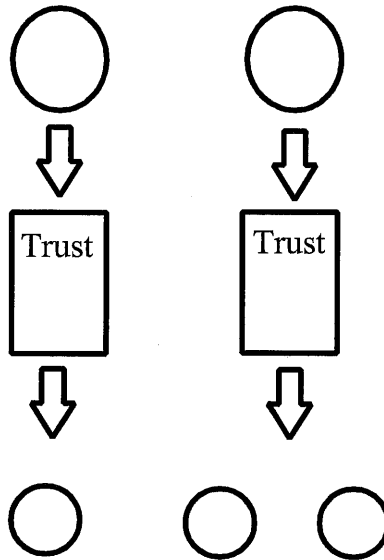
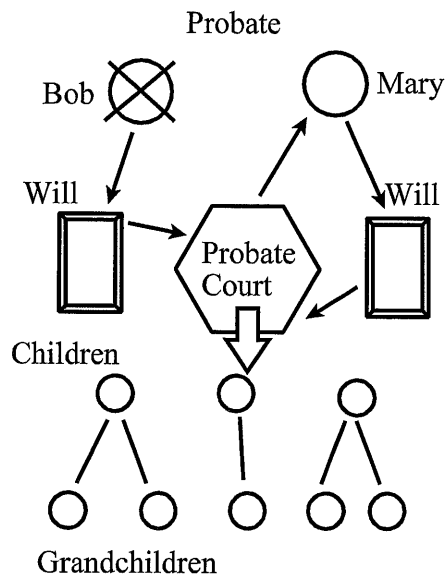

Notes:

Conservatorships and Guardianships

- ◆ Incapacitated persons.
- ◆ Appointed by Court.

For those of us lucky enough to live a long life, we may in our later years face ill health, incapacity or incompetency. If we do, who will pay our bills and manage our financial affairs? *Conservatorships* and *Guardianships* are provided by the law to appoint a Conservator and a Guardian to manage the affairs of an *Incapacitated Person*. However, these can be very expensive, and someone may be appointed that you would not be happy with. For this reason, the use of Powers of Attorney and Living Trusts can give you the opportunity to name the persons you trust to manage your affairs in the event of incapacity, and to avoid the Court process of appointing a Conservator or Guardian. Setting up a Living Trust along with Powers of Attorney is relatively inexpensive compared to the large cost of a Conservatorship or Guardianship in Court.

Conservatorship & Guardianship:

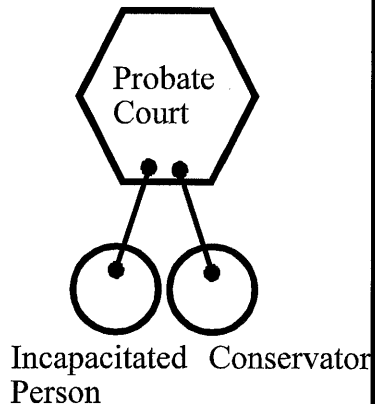

Powers of Attorney:

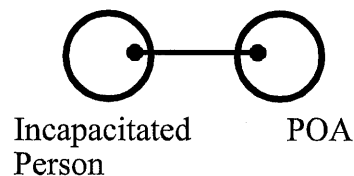

Notes:

Powers of Attorney

- ◆ Durable Power of Attorney.
- ◆ Statutory Power of Attorney.
- ◆ IRS Power of Attorney.
- ◆ Colorado Department of Revenue POA.
- ◆ Limited and Special Powers of Attorney.
- ◆ Springing Powers and Immediate Powers.

A properly drafted ***Power of Attorney*** can protect you from the need for an expensive Conservatorship or Guardianship if you are ever incapacitated or incompetent in later years. They also are very useful if you are ever out of the country or out-of-town during a real estate closing or due to illness or surgery are unable to pay your bills. There are several types of Powers of Attorney to be considered. There is the ***Durable Power of Attorney***, the ***Statutory Power of Attorney***, the ***Special Power of Attorney***, the ***IRS Power of Attorney***, and the ***Limited Power of Attorney***. There is also the ***Springing Power of Attorney*** versus the ***Immediate Power of Attorney***. Each of these should be considered and discussed with the attorney drafting the estate plan. The purpose of a Power of Attorney is to name the person or persons you trust to manage your finances.

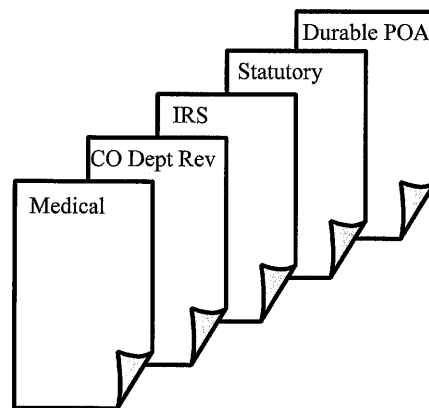

Notes:

Medical Powers of Attorney

- ◆ Naming a person to make medical decisions.
- ◆ Anatomical gifts.
- ◆ Living Will.
- ◆ Advance Directive for Medical/Surgical Treatment.

If you are ill or incapacitated at some time in your life in the future, you will hopefully have already signed a number of medical documents to set out your wishes in advance. The **Medical Power of Attorney** will name a person or persons that you trust to make medical decisions for you, if you are incapable of making those decisions yourself. It will also state whether you wish to make anatomical gifts in the event of death. A **Living Will** and an **Advance Directive for Medical/Surgical Treatment** can set out your wishes in case you ever reach the point where it is no longer feasible to continue life. The law currently allows you to sign a Living Will stating that if you are ever in a coma for seven consecutive days, and two physicians certify in writing that it is an irreversible condition, and if your family consents, then you release the physicians and your family from any civil or criminal liability if artificial life support is terminated. Advanced Medical Directives, Living Wills, and Medical Powers of Attorney are extremely important parts of any estate plan.

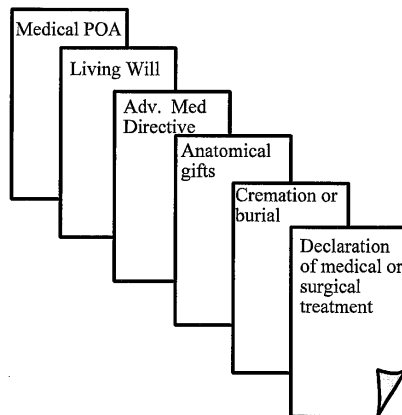

Notes:

Estate taxes

- ◆ \$2 million applicable credit amount.
- ◆ \$12,000 per year gift exclusion.
- ◆ \$2,000,000 generation skipping limit.
- ◆ The use of a Bypass Trust.

If your estate will definitely be less than the federal credit (which reverts to \$1 million in 2011) at the time that both you and your spouse pass away, then there should be no estate taxes under current law. However, if your gross estate for tax purposes, taking into account life insurance and appreciation in value of all of your assets, could possibly exceed the federal credit when both you and your spouse have passed away, then it is certainly important to discuss with the attorney the use of a Bypass Trust to avoid taxes.

<u>Year of Death:</u>	<u>Exclusion:</u>	<u>Tax rate:</u>
<u>2002</u>	<u>\$1,000,000</u>	<u>50%</u>
<u>2003</u>	<u>\$1,000,000</u>	<u>49%</u>
<u>2004</u>	<u>\$1,500,000</u>	<u>48%</u>
<u>2005</u>	<u>\$1,500,000</u>	<u>47%</u>
<u>2006</u>	<u>\$2,000,000</u>	<u>46%</u>
<u>2007</u>	<u>\$2,000,000</u>	<u>45%</u>
<u>2008</u>	<u>\$2,000,000</u>	<u>45%</u>
<u>2009</u>	<u>\$3,500,000</u>	<u>45%</u>
<u>2010</u>	<u>No estate tax this year</u>	
<u>2011</u>	<u>Reverts to \$1,000,000</u>	<u>55%</u>

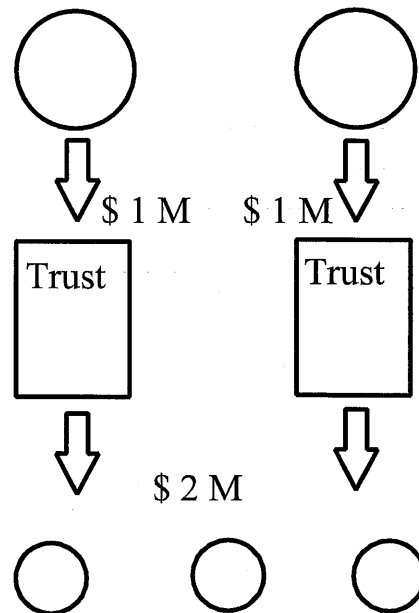

Provisions that should be in a Will

Notes:

- ◆ Two Witnesses and a Notary.
- ◆ Self Authenticating Clause.
- ◆ Appointment of Guardian for Minor.
- ◆ Testamentary Trust for Minors.
- ◆ Identify Family.
- ◆ Disinheriting Heirs.
- ◆ Taxes, Debts and Expenses.
- ◆ Specific Bequests.
- ◆ Residuary Clause.

There are many provisions that should be in a Will. Certainly a Will should be witnessed by two witnesses and notarized. There should be a Self Authenticating Clause. If you have minor children, there should be an appointment of a Guardian for your children to raise and care for them. There should be a Testamentary Trust to manage your children's money until they reach majority. If you have Specific Bequests, those should be set out in detail. Your family members should be listed with full legal names, including any spouse and children. If a child or others are being disinherited, that should be set out clearly so that there is no confusion or misunderstanding after death. The Will should deal with issues such as taxes, debts, and expenses of administration, and there should be a Residuary Clause that deals with who will receive the balance of the estate. If any heir predeceases you, the Will should be clear as to who will receive the deceased heir's share.

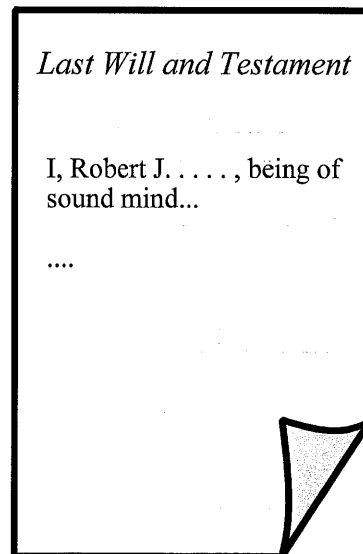

Notes:

Avoiding Probate

- ◆ Probate can be expensive.
- ◆ Time-consuming.
- ◆ Frustrating.
- ◆ Can be avoided with a Living Trust.

Because Probate is time-consuming and expensive, many people elect to avoid Probate by using a Living Trust. Although Colorado has a simplified Probate system which makes Probate less expensive than in some other states, Probate is still a process which takes by law at least six months, and it can cost many thousands of dollars to administer a medium-sized estate. Probate can be avoided with the use of a Living Trust, which also gives your estate privacy and the peace of mind of knowing that your estate is going to the persons who you wish to receive it.

Jones Family Living Trust

Provides for income and use of principal for Grantor's life;

Then for Surviving Spouse;

Then for benefit of children or other heirs.

Appoints a Trustee and grants Trustee power to manage Trust assets.

Avoids Probate.

Notes:

A Living Trust Versus a Will

- ◆ The difference between a **Living Trust** and a **Testamentary Trust**.
 - ◆ The difference between a **Living Trust** and a **Will**.
 - ◆ A Trust **avoids Probate**.
 - ◆ Trusts can pass **out-of-state property** without an **Ancillary Probate**.
 - ◆ A Trust **avoids a Conservatorship**.
-

A *Living Trust* is a document which sets out who you would like to manage your finances if you are incapacitated and what you would like to have happen to your estate after your death. Unlike a Last Will and Testament, a Trust is not Probated and is thus not subject to the delays and expense of the Probate Court process. A Trust is more private than a Last Will and Testament since a Trust is not filed with the Probate Court. Further, a Living Trust can pass out-of-state property without the expense of an Ancillary Probate in another state. A Living Trust is also very useful if you someday become incapacitated, since your trustee can step forward at any time to manage your affairs with a Living Trust. There usually will be no need for a Conservatorship or Guardianship.

Notes:

The cost of Probate

A typical Probate of a small to medium-sized estate can easily cost from **\$2,000 to \$10,000 or more**. For a married couple, the process has to be gone through twice, thus doubling the expenses.

The cost of setting up a living trust.

The cost of setting up a Living Trust, while more than the cost of a simple Will, is far less than the cost of Probate. A Living Trust also avoids the necessity of a Conservatorship if you are ever disabled. At the back of this booklet you will find our current Price List.

Notes:

Funding a Trust

Some attorneys recommend setting up a Living Trust, but not funding it until later. While this is legal, it is better practice to fully fund a Living Trust when it is set up. You should place all of your assets into the Trust so that it will not have to be done after your death. After all, it is easier to do this with your help while you are alive than to try to figure out how to do this with your assets when you are not around to answer questions about what you own. We use a Deed to transfer real estate into the Trust. Assignments are used for most other assets. Our office will assist you with all of the transfers into your Trust.

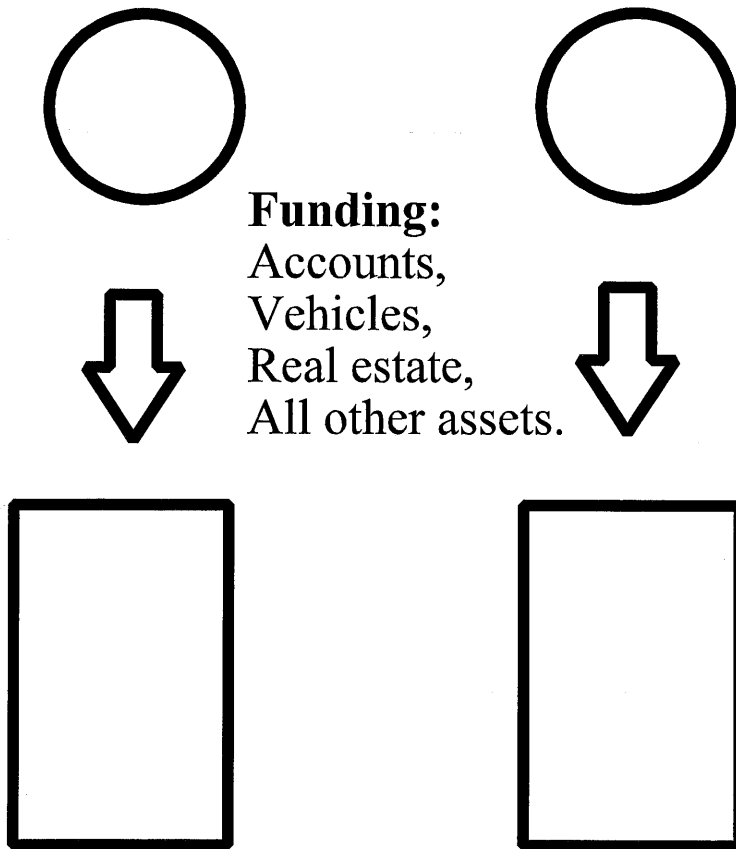

Notes:

The Use of a Bypass Trust

- ◆ Doubling the federal tax credit.
- ◆ \$2 million per person can turn into \$4 million tax free for a couple.

A ***Bypass Trust*** is a specific type of Trust which assists a married couple in doubling the federal tax credit. The federal tax credit is called the "Applicable Credit Amount" and reverts to \$1 million in 2011. The law will certainly change in the future, but no one knows exactly what the credit will be when Congress reviews the laws from time to time. Without a Bypass Trust, a married couple can pass only \$1 million to their heirs without paying large estate taxes. With a Bypass Trust, a married couple can double the applicable credit amount and pass \$2 million dollars to the heirs tax-free. This will save several hundred thousand dollars of taxes. (The rest of the estate over \$2 million would go into the "B" Trust. Sometimes the A and B Trusts are called the "QTIP" or "Marital Trust" and the "Bypass" or "Credit Shelter Trust")

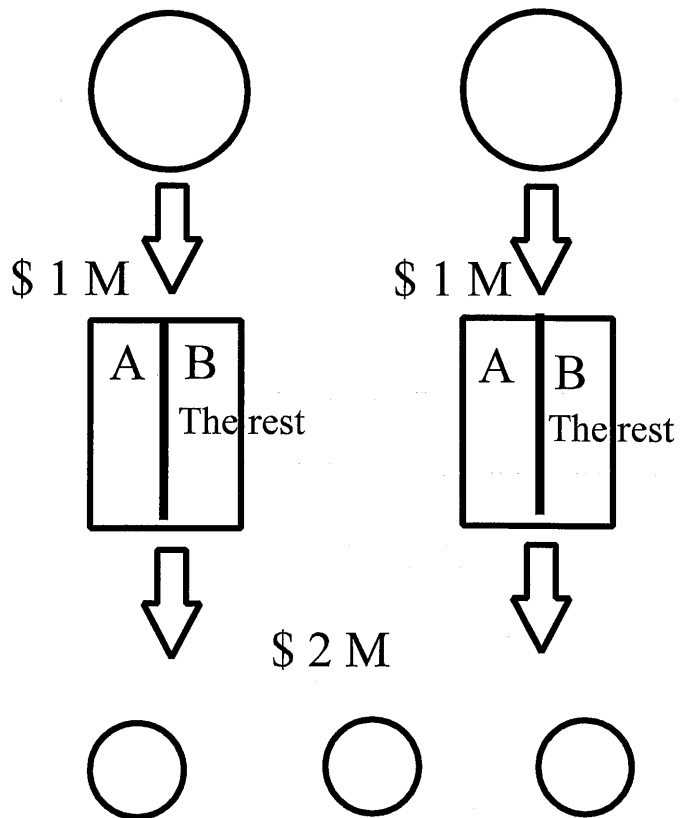

Notes:

The Irrevocable Life Insurance Trust

The death benefit payable from life insurance owned by a decedent at the time of death is **includable** in the taxable estate of a decedent. To avoid including the life insurance proceeds of a large life insurance policy in your taxable estate, an Irrevocable Life Insurance Trust can be used. For taxable estates this can save a large amount of taxes, making more money available for your heirs.

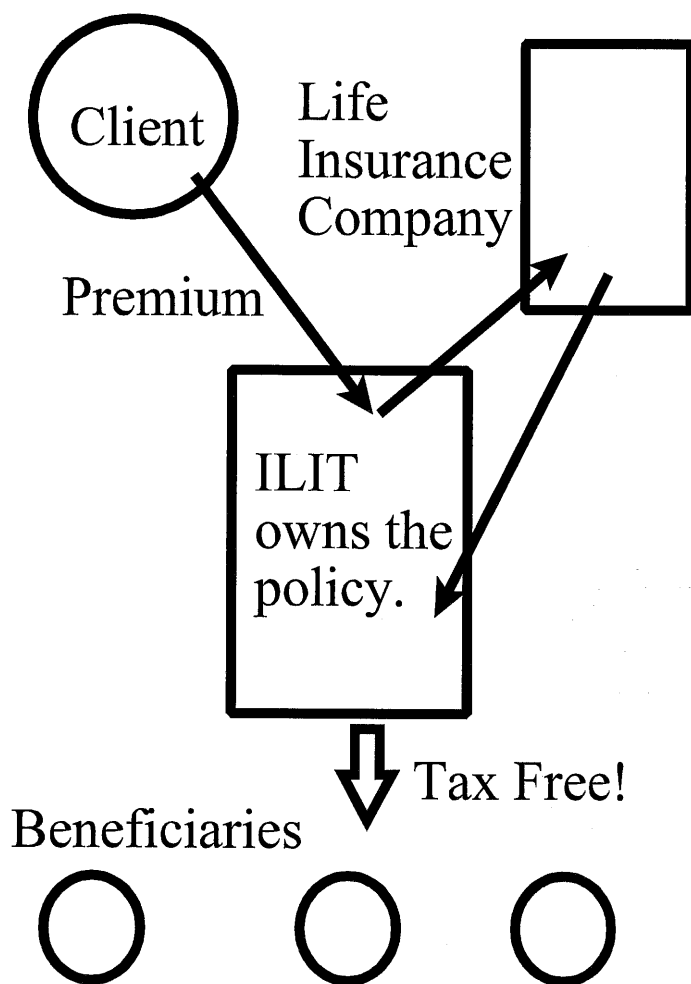

Notes:

The Charitable Remainder Trust

The *Charitable Remainder Trust* is a specific type of trust that can be used in conjunction with the Irrevocable Life Insurance Trust. For highly appreciated assets such as a ranch or apartment building, or stocks that have gone up significantly in value, the Charitable Remainder Trust can be used to **avoid capital gains taxes**. In conjunction with an Irrevocable Life Insurance Trust and the purchase of an annuity, a non-income producing asset can be turned into an income stream for life, with a large bequest to your heirs and to the charity of your choice.

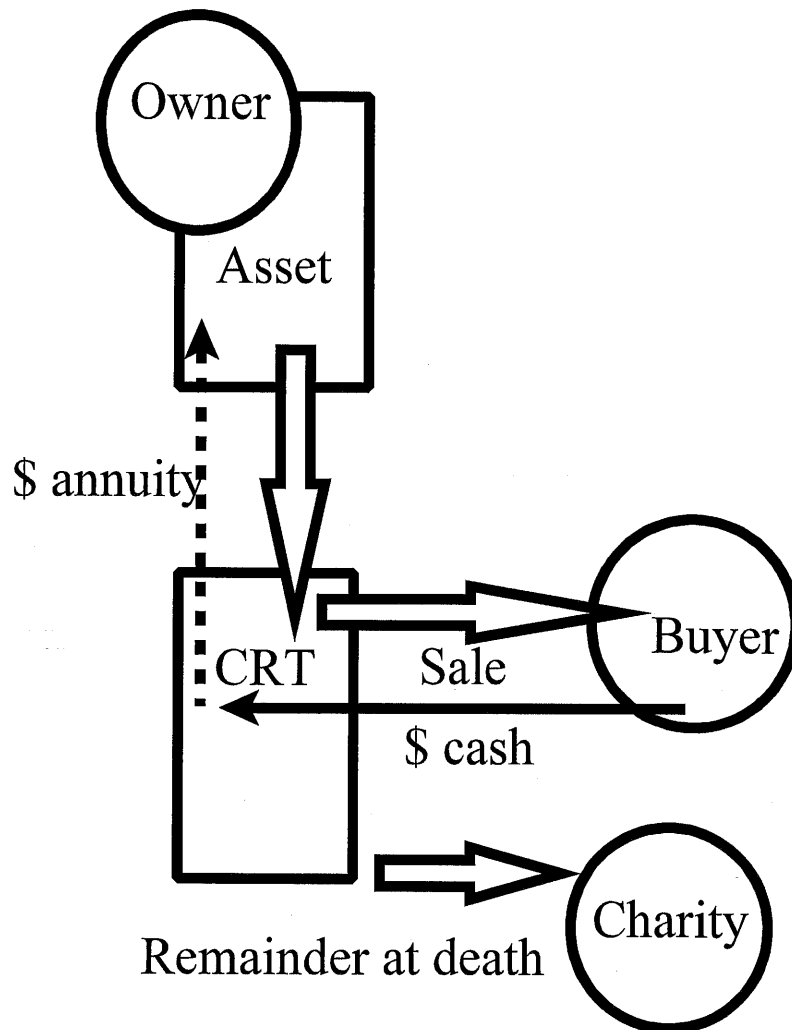

Notes:

Appointment of Guardian; Trusts for minors

For clients with minor children, it is important to provide for who will raise your children. These persons should be carefully considered and named in your Will. A trustee should be appointed to manage the finances of the children until they reach majority.

Guardian

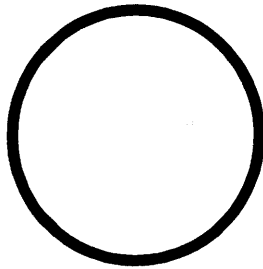

Trustee

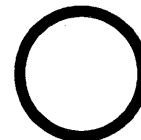
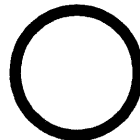
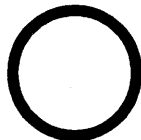
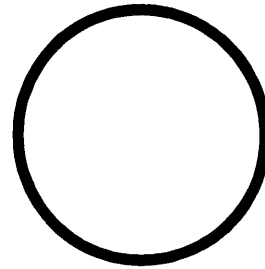

Notes:

Lifetime giving

\$12,000 per year per donee

Current law allows you to give \$12,000 per year to each donee. For very large estates that might be subject to taxes (those over \$2 million under current law as in effect in 2011 for a married couple with two Bypass Trusts) lifetime giving may be a good idea to deplete the estate down to the \$2 million mark.



At \$12,000 per year from each spouse,
\$144,000 can be gifted annually to
three children and their spouses.

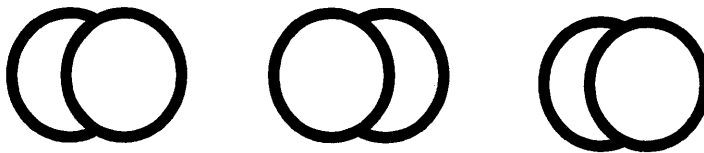

Notes:

Medicaid Planning

- ◆ Long Term Care Insurance
 - ◆ Self-insurance
-

We should consider the possibility that if we live long enough, we may need a nursing home to care for us in our later years. If so, who will pay for that care? With a properly drafted Durable Power of Attorney, the person you name in the Power of Attorney (your "Attorney-in-fact") will have the authority to make transfers to qualify you for Medicaid if need be. Medicaid is essentially a welfare program for persons with low income and minimal assets. For many clients a better option is Long Term Care Insurance for at least **five years**. At the end of three years, with proper planning, Medicaid can kick in to cover nursing home care.

PLANNING CAN BE VERY TECHNICAL!

Divestment Penalty Divisor	\$7,854.00
Income Trust Gross Income Cap	
	\$8,730.00 - Region I
	\$7,776.00 - Region II
	\$7,352.00 - Region III
	\$7,559.00 - Region IV
Income Cap	\$2,205.00
Individual Resource Allowance	\$2,000.00
Monthly Personal Needs Allowance	\$81.95
Community Spouse Resource Allowance	\$120,900.00
Minimum Monthly Maintenance Needs Allowance	\$2,030.00
Maximum Monthly Maintenance Needs Allowance	\$3,023.00
Shelter Standard	\$609.00
Standard Utility Allowance	\$460.00
Resource Allowance for a Couple (Husband and Wife both reside in a facility)	\$3,000.00

Last Updated October 1, 2017

Notes:

Generation skipping

If your estate is large and you would like to set up a *Generation Skipping Trust* for grandchildren and later descendants, a Generation Skipping Trust may be a way to benefit your heirs for generations to come. Current law restricts a

Generation Skipping Trust to \$1,000,000 per person (using 2011 rates) or twice that much for a married couple. With proper management by a Bank Trustee and with anticipated appreciation in value, this could increase in value to a sizable estate for your grandchildren and great-grandchildren. The money is available for education and other needs of your heirs, while being managed by a professional money manager in the Bank Trust Department. You can provide that all of the income be paid out to your heirs annually. Or you can make other provisions for how the money is to be spent, such as for education.

Generation Skipping Trusts

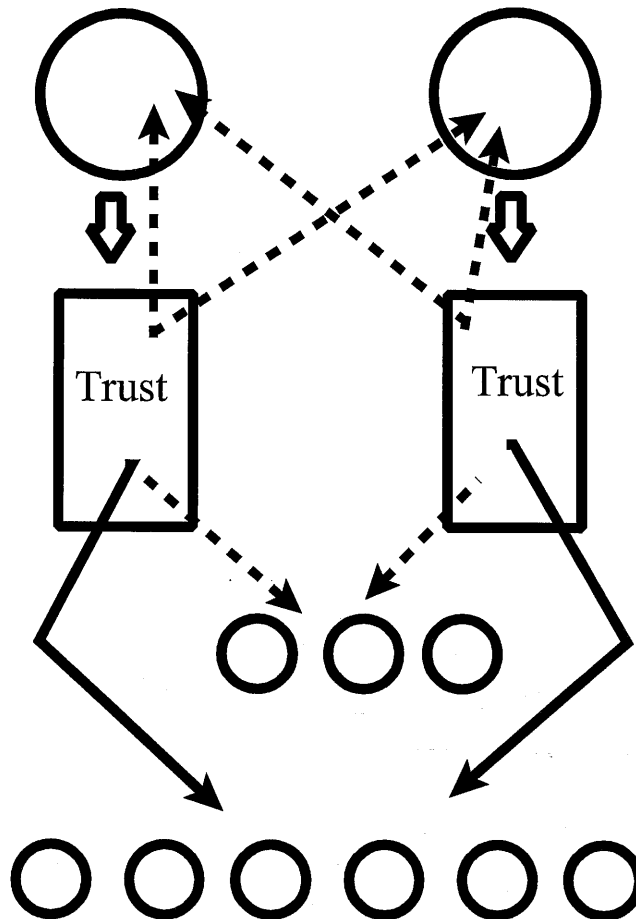

Notes:

Glossary

Some definitions

Adjusted Gross Estate -- your Gross estate for tax purposes less certain allowed deductions.

Ancillary Probate -- a separate Probate proceeding in another state for real property that is owned by the decedent in another state such as a vacation home.

Applicable Credit Amount -- currently \$2 million, the value of an estate which can pass free of estate taxes at death. This was previously called the "Unified Credit."

Beneficiary -- the person who receives your estate under your Will or Trust.

Bypass Trust -- a special type of trust for a married couple. It can be used to double the \$2 million exemption, thereby allowing a married couple to pass \$4 million tax free to their heirs. (Increased to \$5.6 million or \$11.2 million in 2018)

Conservator -- a person appointed by a court to manage the affairs of an incapacitated person.

Credit Shelter Trust -- another word for a Bypass Trust.

Advance Directive for Medical/Surgical Treatment -- a document which relieves a physician from liability if he carries out the family's desires and the decedent's desires to terminate artificial support for a terminally ill patient.

Durable Power of Attorney -- a document which appoints an Attorney-in-Fact for the purposes of managing your finances if you are incapacitated.

Notes:

Executor -- another word for a “Personal Representative.” This is the person who settles an estate under a Will through Probate.

Family Trust -- also called a “Bypass Trust” or “Credit Shelter Trust,” this can be used to double the million dollar exemption to \$4 million for the benefit of a family. The “Family Trust” is also often contrasted with the “Marital Trust” which is solely for the benefit of the spouse. (\$11.2 million in 2018)

Fiduciary -- a fiduciary is a person who is charged by law with heightened responsibilities such as the management of monies under a Will or Trust. Fiduciaries are held to a high standard of responsibility. Examples of fiduciaries include Trustees, Personal Representatives, Conservators, Guardians and Powers of Attorney.

General Power of Attorney -- as contrasted with a Special or Limited Power of Attorney, a General Power of Attorney gives broad authority to the Attorney-in-Fact to manage finances.

Grantor -- also called a Trustor or Settlor, the Grantor is the person who establishes a Trust either for himself or others.

Gross Estate -- for federal estate tax purposes, the gross estate includes the assets of the decedent plus other items as defined by federal law which may be subject to estate taxes.

Guardian -- a person who cares for an Incapacitated Person. The term also refers to a family member named in a Will to care for your children after your death until their majority.

Immediate Power of Attorney -- as contrasted with a Springing Power of Attorney, an Immediate Power of Attorney goes into effect immediately.

Irrevocable Trust -- as distinguished from a Revocable Trust, a particular type of trust which cannot be revoked or amended by the grantor.

Notes:

IRS Power of Attorney -- Form 2848 issued by the IRS allows you to name the person who can file a tax return for you if you are disabled or incapacitated.

Joint Tenancy -- as contrasted with Tenancy in Common, Joint Tenancy is a form of co-ownership in which your co-owner automatically owns your share of the property upon your death.

Last Will and Testament -- a document which directs how your property shall be distributed at your death. A Will is normally Probated through the Probate court in the county in which you resided at death.

Living Trust -- as distinguished from a Testamentary Trust, a Living Trust is set up during your life. The Trustee that manages the Trust makes payments as directed in the trust document.

Living Will -- a document which provides that the signer wishes to have artificial life-support terminated in a hopelessly terminable illness.

Long-term Care Insurance -- a type of insurance which will pay for nursing home care.

Marital Trust -- a type of trust which pays income for life to the surviving spouse.

Medicaid -- a federal program which will pay for nursing home care if income and assets are below a certain level.

Medical Power of Attorney -- a document which names the person or persons who may make medical decisions for you if you are incapable of making those decisions yourself.

Notes:

Multiple Probate -- this term refers to the necessity of having Probate in more than one state if you own real estate in more than one state. This can be avoided by using a Living Trust.

Payable on Death (P. O. D.) -- a designation on a bank account or other investment which states to whom the account would be paid on your death.

Personal Representative -- another term for "Executor," the person who will settle your estate through Probate under your Will.

Personal Property -- all the property that you own other than real estate.

Pourover Will -- a Last Will and Testament which pours over to a Living Trust.

Power of Attorney -- a document which names the persons who will handle your finances in case of incapacity.

Probate Estate -- that portion of your estate passing through the Probate Court.

Probate -- the process of probating a Will through the Probate Court.

Protected Person -- an incapacitated person over whom the Court has jurisdiction in a Guardianship or Conservatorship.

Qualified Terminable Interest Property (QTIP) -- a special type of Marital Trust which allows a married person to control the disposition of the Trust yet still retains the Marital Deduction. All income from the Trust is paid to the surviving spouse, and upon the death of the surviving spouse, the Trust is then paid to the decedent's heirs.

Quit Claim Deed -- a special type of deed which can be used to transfer assets into a Trust. No warranty of title is made, unlike a warranty deed.

Notes:

Real Property -- as distinguished from personal property, real property is a term which refers to real estate such as lands and buildings.

Revocable Trust -- a Living Trust where the grantor retains the right to revoke or amend the Trust.

Special Power of Attorney -- a type of Power of Attorney which is granted for only a special purpose, such as for a particular real estate transaction only.

Specific Bequests -- paragraphs of a Last Will and Testament which provide for specific items to go to certain persons. For example, "my grandfather clock to my son John."

Springing Power of Attorney -- this is a special type of Power of Attorney which springs into effect on the occurrence of a special event such as disability.

Statutory Power of Attorney -- a Power of Attorney form created by statute which must be accepted by any bank or brokerage.

Stepped-Up-Basis -- an increase in your tax basis at time of death which will save your heirs capital gains taxes.

Successor Trustee -- the Trustee that takes over after the death, incapacity, or resignation of a previous Trustee.

Taxable Estate -- the Gross Estate less certain deductions.

Tenancy-in-Common -- a form of co-ownership which does not include a right of survivorship, as distinguished from Joint Tenancy.

Testamentary Trust -- a Trust created in a Last Will and Testament, as distinguished from a Living Trust.

Testator -- a person who dies with a Will.

Notes:

Testatrix -- a female person who dies with a Will.

Transfer on Death (TOD) -- a type of account which names a person to whom it is transferred upon death.

Trust -- a document created by a Grantor which designates a Trustee to manage assets.

Trustee -- the person who manages a Trust, often a trust department of a bank or a trusted individual.

Trustor -- another word for a Grantor, the person who sets up a Trust and transfers assets to it.

Unified Credit -- now called the "Applicable Credit Amount," it shelters \$1 million from estate taxes.

Unlimited Marital Deduction -- a deduction available to shelter all assets given to a surviving spouse at death.

Warranty Deed -- a type of deed for real estate wherein the title to the property is warranted by the Grantor, as distinguished from a Quit Claim Deed which only transfers whatever interest the Grantor may in fact own.

Will Substitutes -- methods of transferring property without Probate, such as a Living Trust, Joint Tenancy property with right of survivorship, life insurance, and payable-on-death accounts.

Notes:

Price List

Complete estate plan including drafting:	Per person:
◆ Last Will and Testament	\$750
◆ Living Trust	\$2,500
◆ Durable Power of Attorney	\$500
◆ Colorado Statutory Power of Attorney	\$500
◆ IRS Power of Attorney	\$200
◆ Colorado Power of Attorney	\$200
◆ Medical Power of Attorney	\$500
◆ Living Will	\$500
◆ Advance Directive for Medical/Surgical Treatment	\$500
◆ Specific Gifts Upon Death	\$150
◆ Competency Exam	\$125
◆ Statutory Signing Questions	\$125
◆ Other ancillary documents	<u>\$500</u>
◆ Total per person if no package	\$7,050

Other Services:

Draft Irrevocable life insurance trust	\$5,000.00 per person
Draft Charitable remainder trust	\$7,500.00 per person
Conferences	Billed separately
Draft Quit Claim Deeds	\$500.00 each
Draft Transfer documents	\$750.00

We request payment before we begin work. Thank you for your business!

DRAFTING PACKAGES:

Example A; Single person without Trust

Draft Complete Estate Plan without trust: \$2,000

Example B; Married Couple without Trust:

Draft Husband Complete Estate Plan without trust: \$2,000

Draft Wife Complete Estate Plan without trust: 2,000

Total \$4,000

Example C; Married Couple with Trust

Draft Husband Complete Estate Plan with Trust: \$2,500

Draft Wife Complete Estate Plan with Trust: 2,500

Draft Transfer documents 750

Draft Quit Claim Deed on real estate (each) 500

Total \$6,250

Example D; Married Couple with Bypass Trust (Large Estate)

Draft Husband Complete Estate Plan with Trust: \$5,000

Draft Wife Complete Estate Plan with Trust: 5,000

Draft Transfer documents 750

Draft Quit Claim Deed on real estate (each) 500

Total \$11,250

Example E; Single Person with Trust

Draft Complete Estate Plan with trust: \$2,500

Draft Transfer documents 750

Draft Quit Claim Deed on real estate (each) 500

Total \$3,750

ADDITIONAL BILLING FOR CONFERENCES AND OTHER WORK:

Time expended by attorneys and staff for conferences and legal services beyond the above drafting is billed at our regular rates. A retainer is required for those services, along with our standard fee agreement.

Date: _____

Client

Client

Order Form

- Example A; Draft **SINGLE PERSON** complete estate plan **without Trust**. \$2,000 _____
- Example B; Draft **MARRIED COUPLE** complete estate plan **without Trust**. \$4,000 _____
- Example C; Draft **MARRIED COUPLE** complete estate plan **with trust** \$6,250 _____
- Example D; Draft **MARRIED COUPLE** complete estate plan **with bypass trust** \$11,250 _____
- Example E; Draft **SINGLE PERSON** estate plan **with trust** \$3,750 _____
- Draft Irrevocable Life Insurance Trust \$5,000 _____
- Draft Charitable Remainder Trust. \$7,500 _____
- Draft QPRT, CRAT, GRAT, etc. \$10,000 _____
- Draft Extra Quit Claim Deeds for additional properties. . . . quantity: ____ x \$500 _____
- Conference time will be billed later; see Fee Agreement. _____
- Other services, please describe _____

TOTAL \$ _____

Terms: **Payment is appreciated in advance.** Please read and sign the Engagement Letter and the Fee Agreement. Additional time and services will be billed separately. You will be charged for any consultation time. We appreciate payment for consultations at the time of services.

Date: _____

Client

Client

ESTATE PLANNING WORKSHEET

Information provided is held in complete confidence, and is used for the sole purpose of analyzing estate planning needs and designing estate planning documents.

During the initial appointment, we will determine your specific estate planning needs and goals. The potential cost of probate and tax which would occur with your current plan will be analyzed, and methods of reducing costs and accomplishing goals will be discussed. An exact quote on fees for estate planning will be provided *before* you decide to authorize completion of your estate plan.

KAIN & BURKE, PC

ATTORNEYS AT LAW

PO Box 1981

Grand Junction, CO 81502

(970) 241-2969 – (970) 241-3129 FAX

www.kainlaw.com

ESTATE PLANNING WORKSHEET

The information requested on this worksheet may seem like none of our business, but it is very important that an estate planner understands your present situation and your wishes for the future. This information enables us to plan the estate to accomplish future goals and to save on taxes and administrative expenses.

If you are married and all information on this worksheet is identical for you and your spouse, complete only one worksheet. If information for each spouse differs, make a copy of this worksheet so each spouse has a separate one. For those of you who are single, we apologize for phrasing everything based on husband and wife. This is for simplicity of the form only. To complete this worksheet, please fill in the wife's blanks if you are female and the husband's blanks if you are male. Estate planning is very important for singles as well as couples. Plan of distribution for singles is not obvious and most or all assets will be probated since joint tenancy with a spouse is not an available method of avoiding probate.

Date _____ Phone Number(s) _____

HUSBAND	First	Middle Name	Last
---------	-------	-------------	------

Date of Birth	Social Security Number
---------------	------------------------

WIFE	First	Middle Name	Last
------	-------	-------------	------

Date of Birth	Social Security Number
---------------	------------------------

Street	City	State	Zip
--------	------	-------	-----

County _____

Marital Status: Married Divorced
 Separated Single (including widowed and not remarried)

What is your primary motivation for considering estate planning? (*Select one or more*)

- Probate avoidance
- Guardianship for minor children
- Business or farm planning
- Federal estate tax planning
- Other _____

How soon would you like to complete planning? Is there a specific deadline, such as an upcoming trip, surgery, etc.? _____

	Husband		Wife	
Do you presently have a will?	Yes	No	Yes	No
Do you presently have a trust?	Yes	No	Yes	No
Are you interested in avoiding probate of your estate?	Yes	No	Yes	No
Were there any previous marriages?	Yes	No	Yes	No
Are any of your children not from your current marriage?	Yes	No	Yes	No
Has anyone in your family conceived a child or is anyone planning to conceive a child by assisted reproductive technology, including but not limited to: being a sperm donor, being an egg donor, receiving an embryo, or having a child through surrogacy or any other assisted technology?	Yes	No	Yes	No
Are any of your children adopted?	Yes	No	Yes	No
Do any of your children or other beneficiaries have disabilities?	Yes	No	Yes	No
Do you own a farm or business?	Yes	No	Yes	No
If yes, do any of your children work in the business with you?	Yes	No	Yes	No
If yes, does the child working in the business have an ownership interest in the business?	Yes	No	Yes	No
Are you a U.S. citizen?	Yes	No	Yes	No
Have you entered into any agreements with your spouse (such as a prenuptial or community property agreement)?	Yes	No	Yes	No
Are there any serious health problems? If yes, please describe briefly: _____	Yes	No	Yes	No

Do you own a long-term care (nursing home) insurance policy? Yes No Yes No

Do you own any firearms? Yes No Yes No

If so, who would you like to receive them upon your death _____

NET WORTH: If you added the value of all property owned by yourself and your spouse including real estate, personal property, bank accounts, stocks, bonds, IRAs, and anything else you own except death benefits on life insurance, what is the approximate total value of the estate of yourself and your spouse? _____

What is the value of death benefits on life insurance? Insuring Husband _____ Insuring Wife _____

What is the total amount of your outstanding liabilities? _____

INCOME/ASSET/LIABILITY INFORMATION

Please list your income/asset/liability information in the appropriate category below.
Attach a separate page if necessary.

	Husband	Community/Joint	Wife
INCOME:			
Earned Monthly Income from Labor	_____	_____	_____
Monthly Social Security Income	_____	_____	_____
Monthly Pension Income	_____	_____	_____
Other Monthly Income	_____	_____	_____

Type of Asset	Title in Which Held (Husband sole, Wife sole, Joint with spouse, Joint with third party, Tenants in Common, etc.)	Current Value
REAL ESTATE (include type of property e.g., residential, agricultural, commercial, or manufacturing)		
Personal Residence		
Vacant Land		
Other:		
LIQUID ASSETS (include Account Number and where held)		
Cash on Hand		
Stocks		
Bonds		
Money Market Accounts		

Type of Asset	Title in Which Held (Husband sole, Joint with Spouse, Joint with third party, Tenants in Common, etc.)		Current Value	
Equity in Business ___ Sole Prop. ___ Partnership				
Notes and Loans Receivable				
Checking Accounts				
Savings Account				
Certificates of Deposit				
Automobiles				
Other Personal Property				
Annuities	Owner	Beneficiary	Current Value	
IRAs				
Pension/Profit Sharing				
Life Insurance			Cash Value	Death Benefit
Other Assets				
LIABILITIES	Name Loan Taken In: (Husband, Wife, etc.)		Amount Owed	

CHILDREN OR OTHER BENEFICIARIES

Name	Address	Date of Birth	Relationship

GIFT TAX RETURNS

Have gift tax returns ever been filed to report gifts made? _____ ***If YES, please bring copies of the returns to your appointment.

APPOINTMENTS

1. **PERSONAL REPRESENTATIVE.** The will should name a personal representative to probate the estate. (Personal representative is also sometimes referred to as executor or administrator, e.g., spouse as primary personal representative, with a child, relative, friend, or corporate trustee as alternate. In second marriage situations, spouse as primary personal representative may not be appropriate.)

PERSONAL REPRESENTATIVE: _____

ALTERNATE: _____

SECOND ALTERNATE: _____

2. **SUCCESSOR TRUSTEE.** If you choose to avoid probate of your estate by executing a living trust during lifetime, a successor trustee should be named. The successor trustee would be responsible for managing assets if you were unable, or in the case of a joint trust, if neither you nor your spouse were able, to manage assets due to incompetence. The successor trustee would distribute assets to beneficiaries after death, or in a joint trust, when neither you nor your spouse survives.

SUCCESSOR TRUSTEE: _____

ALTERNATE: _____

SECOND ALTERNATE: _____

3. **HEALTH CARE AGENT.** Who should be named to make medical decisions on your behalf including decisions regarding medical consents, life support issues, and nursing home admission if you were unable to make these decisions yourself? (Frequently, the primary agent is the spouse.) It is not necessary to appoint the same person who is your successor trustee or personal representative as your health care agent.

HEALTH CARE AGENT: _____

ALTERNATE: _____

SECOND ALTERNATE: _____

PLAN OF DISTRIBUTION

1. **SPECIFIC GIFTS.** Do you want to make charitable gifts, such as to a house of worship or other institution? Do you wish to make a special gift to a particular person, such as a piece of jewelry to a particular child?

2. Briefly describe where you would want assets remaining after any specific gifts are distributed. (Don't worry about tax planning or other considerations in answering this question. We'll consider those details later if needed.)

___ All to spouse; then equally between children, and if a child didn't survive, the deceased child's children would take the share of the deceased child.

___ All to spouse, then equally between surviving children.

___ All to spouse, then _____

___ As follows: _____

3. **ULTIMATE DISTRIBUTION.** You might want to provide for the distribution of your property if neither you, your spouse nor your children/other beneficiaries named above survive.

PLEASE COMPLETE THIS SECTION ONLY IF YOU HAVE MINOR BENEFICIARIES OR BENEFICIARIES WITH DISABILITIES

1. **GUARDIAN.** If you have minor children or a beneficiary with special needs, you may need to appoint a guardian. The guardian is responsible for the day-to-day care of the child. It is a good idea to name an alternate guardian to act if your first choice cannot serve.

GUARDIAN: _____

ALTERNATE: _____

2. **TESTAMENTARY TRUSTEE.** You may need a trustee to manage assets for beneficiaries until they reach an age when you believe they should be capable of managing assets on their own. A trustee can keep the beneficiary's money invested wisely and use it for their education, support, etc., until they reach the age specified for outright distribution of assets to them. The trustee can be a relative, friend, trust company, or other person or institution you trust to manage and distribute assets according to your wishes. The testamentary trustee can be the same person named as the guardian, or could be a different person or institution.

TESTAMENTARY TRUSTEE: _____

ALTERNATE: _____

3. **AGE OF DISTRIBUTION.** If you do establish a trust to allow a third party to manage assets for beneficiaries, then it is necessary for you to decide when the beneficiaries will be mature enough to manage assets on their own. You may want to give each beneficiary his or her share at the time the beneficiary reaches a particular age. You may consider splitting the distribution, such as 1/2 at age 25 and the balance at age 30, or 1/3 at 21, 1/3 at 25, and 1/3 at 35. You may use any age or combination of ages that you choose.



225 N. 5TH St. # 611
PO BOX 1981
GRAND JUNCTION, CO 81502
PHONE: (970) 241-2969
FAX: (970) 241-3129
WWW.KAINLAW.COM

ATTORNEY/CLIENT ENGAGEMENT AGREEMENT FOR ESTATE PLANNING

Joint Representation for Married Couple With Waiver of Conflict

Thank you for engaging this law firm to represent you in drafting your estate plan. Please read this Engagement Agreement carefully before signing, and ask first if you have any questions or concerns. This Engagement Agreement includes a waiver of conflict of interest so that the law firm can represent both of you. If you prefer to hire separate lawyers from separate independent law firms for each of you, you should not sign this agreement.

- Services to be provided.** This law firm will draft a complete estate plan for the two of you, and deliver to you all documents for signing at our office. Please select from the price list and order the services which you would like to be provided. We will meet with you and recommend which plan we think best serves your needs as a couple. Ultimately, the decisions regarding your joint estate plan are yours to make together.
- Payment.** We appreciate payment in advance. Please see the price list and order form which you will be asked to sign at the same time you sign this agreement. The price list includes flat fees for drafting the documents.
- Conference time and additional services.** Our flat fee estate plans listed on the price list and order form do not include conference time. We will bill for any conference time and for any additional services not included in the standard estate plan packages at our regular hourly rates, which you agree to pay promptly upon receipt of the bill. Payment for conferences at the conclusion of each conference is greatly appreciated.
- Flat fee and hourly fees.** We charge a flat fee (as disclosed on our price list) for drafting estate planning documents. Please see the fee disclosure and order form. We also charge an additional “hourly fee” for all conferences and for additional services that you might need which are not part of the standard estate planning drafting document package that you select. You will receive a bill for any conferences or additional services. Attorney time and staff time not covered by the flat fee for drafting are billed according to the standard Fee Agreement. A retainer is put up along with the Fee Agreement.

Therefore, there are two portions of your billing, as follows.

- The flat fee for drafting.
- The additional Fee Agreement with retainer for conferences and other work not included in the drafting of the basic documents.

5. **Right of rescission.** You have the right to rescind this agreement and obtain a refund in full if you notify us in writing within three (3) days of signing this agreement.

6. **When fees are earned.** After we draft the estate plan and you have signed the documents, we will consider all fees to have been earned, and we will transfer your funds from our trust account to our operating account at that time. If you change your mind after three days but before the estate plan is completed and signed, we will charge for our services depending on the amount of time and effort we have expended, and we will refund the balance.

7. **Referrals.** We receive referrals from other professionals and provide referrals to our clients to go to other professionals. This law firm is independent of any other professional from whom, or to whom, a referral may be made. Each professional takes full responsibility for his or her work, and is not responsible for the work of the independent professional. We do not share or split fees with any other professional. Any fees due to your CPA, financial planner, insurance agent, stockbroker, etc. should be discussed directly with that professional and paid by you to that professional. Also, we do not take responsibility for the work that professionals you hire may do for you, and if you are not satisfied with their work for any reason, you must look only to them for satisfaction.

8. **Confidentiality and privacy policy.** Everything you tell your attorney or our staff is confidential. We will respect your right to privacy and not discuss your affairs outside of the office with anyone. We will not disclose any information nor share any documents without your permission. However, if you are working with other professionals with regard to your estate planning, such as a certified public accountant, a stockbroker, a financial planner, an insurance specialist, a banker, or any other professionals, you agree to waive any confidentiality so that we may speak to them and share documents, and work with them to better serve you. Please let us know, both in writing and verbally, if there are any restrictions that you wish to place on that.

9. **Waiver of conflict.** If you are married and asking this law firm to represent both of you, you need to understand the information provided below.

a. **Right to two independent attorneys.** Each spouse has the right to independent counsel. By signing this agreement, you are foregoing that right and choosing to have one attorney represent both of you jointly.

b. **Waiver of conflict of interest.** There is an inherent conflict of interest when one attorney represents two clients, and this is true of spouses who have one attorney draft an estate plan for both of them. By choosing to have this law firm represent both of you for your estate planning needs, you are waiving any conflict of interest when you sign below.

c. **Disadvantages of joint representation.** There are disadvantages to joint representation. Neither of you will be able to speak to the attorney confidentially as to the other spouse, because the expectation is that all information will be shared with both spouses. There will be no secrets between spouses. The two of you and your attorney will be meeting together in all of our consultations, and will be avoiding phone calls and meetings where one spouse is not

present. Our law firm will try to devise the best plan for the two of you jointly. However, two separate attorneys might have made a different recommendation to each of you individually. Spouses can have differing and sometimes conflicting interests and objectives regarding their estate planning. For example, in some cases to save estate taxes, we recommend transfers between spouses. If you had independent attorneys, an independent attorney might not recommend that in some situations. Another problem that can arise from dual representation is that restructuring assets and other advice given regarding estate planning might be inconsistent with strategies that would be taken if your marriage ever were to end in divorce. You also might have differing and irreconcilable ideas on how your estate plan should be structured, but may not want to talk about that in front of your spouse. There are many other examples of problems that can arise because you do not have independent attorneys for each of you. If you each had a separate lawyer, you each would have an advocate for your position and would receive totally independent advice. Our firm cannot be an advocate for one of you against the other in a joint representation situation. By signing this agreement, you are stating to us that you nevertheless have chosen joint representation as being best for you, and that you understand that there are risks and disadvantages to joint representation, and that you accept those risks and disadvantages.

d. **Agree to no secrets.** You agree, as spouses, that by selecting this law firm to represent both of you with regard to your estate planning needs, you will keep no secrets from the other spouse or from the attorney. You agree to disclose to your spouse and to your attorney all relevant facts, and to hide nothing. You will not tell the attorney anything that you ask the attorney to keep confidential from the other spouse. You both waive any right to confidentiality as to the other spouse, and agree that the attorney may tell the other spouse, at his discretion, anything that you tell the attorney. You give permission to the attorney to share with your spouse any information, whether received by you or from another source, and whether received by you during this process of estate planning or previously (such as during prior representation of one spouse alone). You both also agree that the attorney, at his or her discretion, may keep anything said confidentially by the other spouse from you if your spouse breaches this agreement by telling the attorney something confidential. You both agree not to put the attorney in the middle by asking the attorney to keep secrets from your spouse. You also agree that you will both carry out the estate plan agreed upon, and will not secretly do anything to defeat the estate plan or change the estate plan without full disclosure to your spouse. Further, you both agree to share with each other and with the attorney all relevant information, all pertinent documents, and any details of prior transactions that may be important to estate planning. There will be no secrets between the two of you or with the attorney, such as the existence of prior children out of wedlock, or questionable business transactions, tax problems or debts in the past. The attorney reserves the right to terminate representation of either or both of you if either of you breaches this agreement, or if irreconcilable conflicts arise that, in the attorney's opinion and sole discretion, make joint representation difficult, unethical or impossible for the attorney to continue such joint representation. Our firm reserves the right to continue to represent one of you with regard to services not related to the estate plan (especially if we have a long-standing relationship with one of you) if such continued representation will not prejudice the other spouse. The two of you and your attorney also might mutually agree to our firm representing one of you with regard to the estate planning if the other chooses to go to a separate attorney, so long as there is no confidential information that makes that impossible.

10. **One year limited guarantee.** We will make free revisions to your estate plan for a full year after the date you sign your estate plan in the unlikely event that you find that we have made any mistakes in drafting. You agree to carefully review all of the documents we prepare and advise us within the year if you find any errors. Additional meetings during the year, and any revisions after the year, will be billed at our hourly rates then in effect.

11. **Your other obligations.** You agree to provide full and complete disclosure to us and to your spouse of all information necessary for us to prepare your estate plan. You also agree to read your estate plan carefully to ensure that it meets your needs and satisfies your desires, and to make sure that you understand it. Please ask us if you have any questions.

12. **Completion of services.** After you have signed your estate plan, we will keep a copy, and we suggest you keep the original estate planning documents in a safe place such as a safe deposit box at a bank. We consider our legal services to you to be complete at that time. Except for the one-year free revision policy stated above, we do not undertake a continuing responsibility to you with regard to your estate plan unless you come back and hire us for specific tasks. For example, with the large number of clients that we have serviced over the years, it will not be possible for us to contact you and all our other former clients every time the state laws relevant to estate planning and probate change, or when the tax laws change. Therefore, we recommend that you take the initiative to call to make an appointment every two to five years (or more often if you desire) to come back and consult with us regarding whether your estate plan is still appropriate for you, given the status of the law at that time and your particular family circumstances then.

Please feel free to call the attorney or the attorney's paralegal if you have any questions about the above, or if you have other questions or concerns throughout the process. Thank you for hiring this law firm. We look forward to working with you.

We have read and we agree to the above.

Date: _____

Clients:

(signature)

(signature)

Kain & Burke, PC

By: _____

Documents Helpful for Estate Planning

Please bring with you, if at all possible, the following documents to your next meeting with the attorney regarding estate planning:

- Copies of any **prior estate planning documents** that you may have signed, such as your Last Will and Testament, any Living Trust, any Powers of Attorney, etc.
- Copies of all **life insurance** policies with beneficiary designations. Be sure to get an address where changes are to be mailed if it is not on the policy.
- Copies of the **warranty deeds** on any real estate you own.
- Copies of the most recent **statements** for any bank accounts, certificates of deposits, money market accounts, mutual funds, or other investments.
- Copies of the most recent **statements** concerning any IRA, annuity, 401(k), or other retirement account.
- A **listing** of all investments and major assets with their approximate value.
- Copies of **motor vehicle titles** (or registrations if you do not have the title yet).
- The name, address and phone number of your **stockbroker**, if you have one.
- Your completed **questionnaire**.

The above will be very helpful when you meet with the attorney at your next appointment. Please try to be as complete and honest as possible with all information. This will help us help you better. All of the information and documents will be kept strictly confidential.